

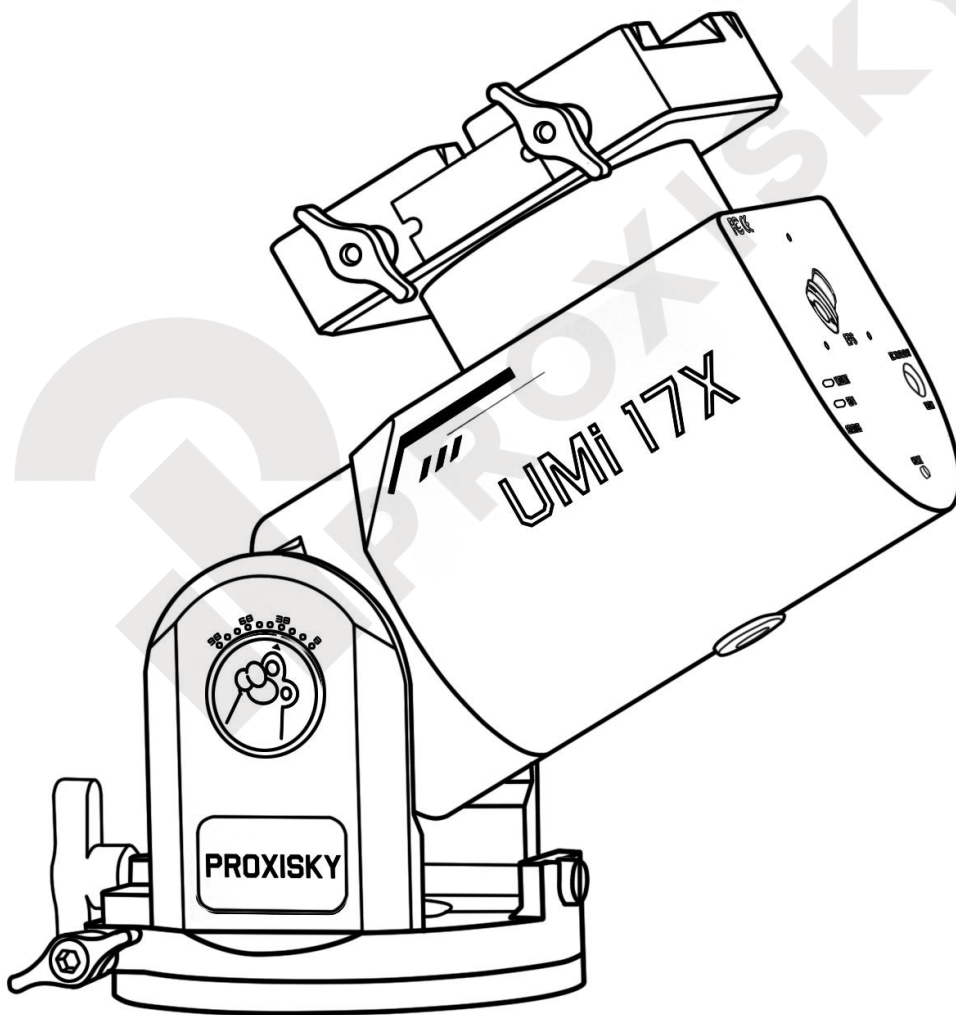

UMi 17X Servo Direct-Drive Strain Wave Gear Equatorial Mount User Manual



Revision Log

Date	Version	Details
2025.10	V1.0	Initial Release



Preface

Thank you very much for choosing the all-new UMi 17X servo direct-drive strain wave gear equatorial mount (hereinafter referred to as the UMi 17X).

While maintaining the exceptional performance from its predecessors, the UMi 17X shoulders our expectations being the latest of our flagship models. Equipped with servo motors on both axes, each unit of UMi 17X now comes with a PE test report on its type-17 strain wave gears on RA, with periodic error less than ± 10 arc-seconds. The UMi 17X can support equipment up to 12kg without a counterweight and up to 18kg with counterweights*¹.

The UMi 17X now comes with both home sensors and RA limit sensors with adjustable limit angles, as well as the previously introduced Anti-Collision System (ACS). In addition to the regular home sensors, a secondary home sensor is placed on the Declination axis, supporting an alternative physical home position when a dual parallel setup is needed.

To simplify its design and offer maximum convenience for cable management, the dovetail saddle on the UMi 17X now provides a DC power output supporting up to 10A at 12V, and an additional USB Type-C port for serial communication with the mount. Both USB Type-C mount ports come with standard screw holes for locking plugs to ensure stable connection.

We are also taking a huge leap forward in terms of wedge design on the UMi 17X. The altitude adjustment mechanism is now stop-less, and any latitude between 0 and 90 degrees can be achieved by simply turning the altitude adjustment knob at the back of the mount, while still enjoying the self-locking and backlash-free experience.

Once again, thank you for choosing the UMi 17X strain wave gear equatorial mount and choosing Proxisky. We will strive to bring you a more satisfying astronomical exploration experience. Thank you for your trust and support, and let us together explore the infinite possibilities of the universe!

*¹(Payload weight * 9.8, in kilograms) * (0.09 + Distance from the center of mass of the payload to the saddle, in meters) < 40 N*m, with 0.09 being the distance between the saddle and the center of RA in meters.

Table of Contents

Revision Log	1
Preface	2
I. Safety Instructions	4
1. Safety Tips	4
2. Equipment Installation and Handling	4
3. Standard Operation	5
4. Troubleshooting	5
II. Product Overview	6
1. Introduction	6
2. Specifications	7
3. Packaging (CW shaft optional)	8
4. Item List	8
III. Important Notes	9
IV. Installation	11
1. Body Installation (Equatorial & Alt-Az)	11
2. Connection	15
3. Physical Home	16
4. Secondary Home Position	16
5. Physical RA Limits	17
6. Physical Dec Limits	17
7. UMi Mount Mobile App	18
8. Setup with ASIAIR	18
9. Setup with NINA and PHD2	19
V. Related Drawings	20
VI. After-sales Services	21
VII. Warranty	21

I. Safety Instructions

We highly value the safety of our users. To ensure your personal and financial safety, we strongly recommend that you carefully read and understand all the safety items in this guide before using the equatorial mount. Always follow these safety tips to avoid possible injury or property damage.

1. Safety Tips

- ▲ **Risk of Electric Shock:** Please do not touch the power cable with wet hands to avoid electric shock.
- ▲ **Risk of Electrical Fire:** Do not pull the power cord or battery. Ensure the power cord and battery are undamaged and not short-circuited before use to prevent electrical fires.
- ▲ **Risk of Battery Short Circuit:** When using the battery, ensure the DC plug is inserted correctly to prevent short circuits that could lead to fires or explosions.
- ▲ **Child Safety:** The equatorial mount and its accessories contain small parts that could be swallowed by young children. Children under the age of 12 should not use this device. Minors under the age of 18 should operate it under the supervision and guidance of a guardian.

2. Equipment Installation and Handling

- ▲ **Equipment Transportation:** Handling the equipment gently can prevent impact damage during transportation.
- ▲ **Equipment Handling:** When handling the equipment, make sure your grip is secure to increase stability and prevent accidental drops, which could cause injury or damage to the equipment.
- ▲ **Equipment Installation and Placement:** Use the equatorial mount on a flat surface. If the mount is not placed at 90 degrees on the base, it may



accidentally fall and cause damage.

3. Standard Operation

- ▲ **Operating Steps:** Refer to the product's operation manual for use and operation of the equatorial mount, strictly following the operating procedures without arbitrarily changing the equipment's position or installation method.
- ▲ **Safety Precautions:** Avoid sudden, forceful adjustments or installations that could cause your hand to hit protruding parts or edges of the equatorial mount, resulting in scratches.
- ▲ **No Disassembly:** Do not disassemble the mount without authorization. If needed, contact after-sales support for professional repair. The equatorial mount is a delicate device, and improper operation or unauthorized disassembly could damage the instrument, directly affecting warranty.

4. Troubleshooting

- ▲ **Abnormal Behavior:** If the equipment behaves abnormally, such as making strange noises or emitting smoke, immediately cut off the power and contact after-sales service.

II. Product Overview

1. Introduction

This product is an equatorial mount using strain wave gear reducers and servo motors, specialized in astrophotography, featuring high precision and payload capacity, ultra-portability, and integrated module for easy cable management. It can be used in either equatorial or altitude-azimuth mode, suitable for astronomical observation, astrophotography, and general celestial tracking.

This mount adopts a lightweight design, making it easy to carry while offering precise control and smart, simple functionality to meet the needs of a wide range of astronomy enthusiasts.

Features

- ❖ **Precision SWG:** Equipped with astronomy-dedicated ultra-high precision type-17 strain wave gear reducer on RA, the UMi 17X achieves outstanding tracking accuracy from dual harmonic design. PE (periodic error) on the UMi 17X is within ± 10 arc-seconds with test report included with each unit.
- ❖ **Cable Management:** DC power output port supporting up to 10A at 12V along with USB Type-C port for communication with the mount located on the saddle.
- ❖ **Payload Security:** UMi 17X comes with physical sensors for both home positions and RA limits, as well as the Anti-Collision System, providing the most reliable-ever and worry-free experiences. RA limits can still be customized to values other than strictly 90 degrees.
- ❖ **Wedge Design:** The first-of-its-kind altitude adjustment mechanism adopted on the UMi 17X now provides a stop-less, self-locking and backlash-free design. Switch to any latitude between 0 and 90 degrees now by simply turning the altitude adjustment knob at the back of the mount.

2. Specifications

Mount Type	German Equatorial Mount
Weight	4.3kg
Material	Carbon Fiber, 6061 Aluminum, 304 Stainless Steel
Finishing	Anodized with Rust-proof Coating
Platform	OnStepX
Modes	German Equatorial/Alt-Az
Supported Software	ASIAIR, NINA, KStars and more
RA	Servo motor, type-17 SWG, Direct Drive
DEC	Servo motor, type-14 SWG, Direct Drive
Payload Capacity	12kg without CW, 18kg with CW
Periodic Error	±10", PE test report included with each unit
Home Position	Physical home sensors with FRAM Additional Dec home sensor for parallel dual-setup
RA Limit	Physical RA Limit Sensor (Software adjustable)
Dovetail Saddle	Vixen-Losmandy
CW Shaft Thread	M12
Input	12-24V, DC 5.5-2.1
Base Type	Backlash-free, Self-locking, Stop-less Design
Base Connection	3/8", 6*M6, supporting CF40 and TC40 tripods
Interface	USB Type-C (Mount & ST4), Wi-Fi, Bluetooth, UMi Mount App
Saddle Connection	USB Type-C Mount, DC power output up to 10A at 12V
GOTO Speed	3.5°/s, max 7°/s*
Braking	RA Electromagnetic Braking, braking power ≥ 48 N·m
Anti-Collision System	Yes, dual-axis
Electronic Polar Scope	Compatible with iPolar, Polemaster

*Recommended GOTO speed is 3.5°/s. Use higher speeds at your own risk, as they may result in serious damage if collision occurs. We disclaim any responsibility for resulting damages to your mount and equipment.

3. Packaging (CW shaft optional)

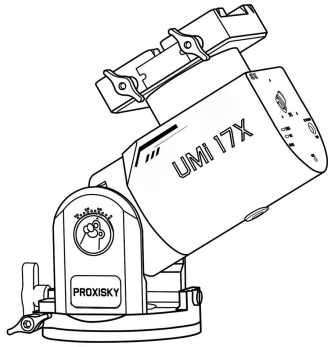

UMi17X Equatorial Mount

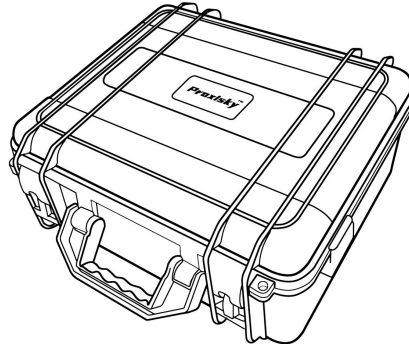

Storage Case

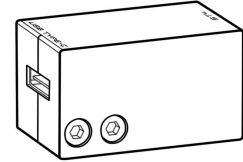

USB Type-C Adapter for ST4 HC

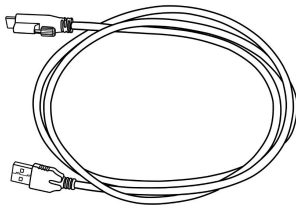

USB Type-C to Type-A Cable with Locking Plug 1.2m

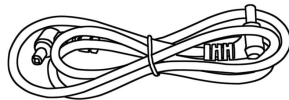

Male-Male DC 5.5-2.1 Cable 1m

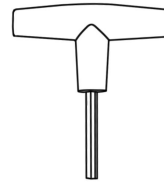

Hex Screwdriver

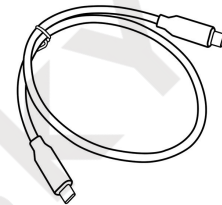

USB Type-C Full Featured Cable for ST4 HC 0.5m

4. Item List

Note: This user manual may not be updated with changes in factory configurations. If the product you receive differs from the list below, please refer to the order configuration information at the time of purchase or contact us.

No.	Item	Quantity
1	UMi 17X Equatorial Mount with Electronic Polar Scope Base	1
2	Male-Male DC 5.5-2.1 Cable 1m	1
3	USB Type-C to Type-A Cable with Locking Plug 1.2m	1
4	USB Type-C Full-Featured Cable for ST4 HC 0.5m	1
5	USB Type-C Adapter for ST4 HC	1
6	M6 Hex Screwdriver	1
7	Storage Case	1

III. Important Notes

A physical home button is located on the front panel of the UMi 17X.
Simply press and hold it down for 2-3 seconds to activate homing which
relies on the built-in physical home sensors.

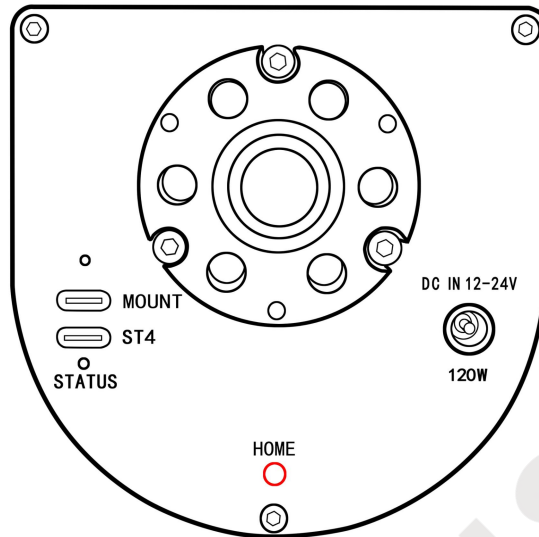

To ensure the best connectivity via USB Type-C, both ports on the UMi
17X come with standard screw holes for USB Type-C cables with
locking plugs, one of which is included with the mount.

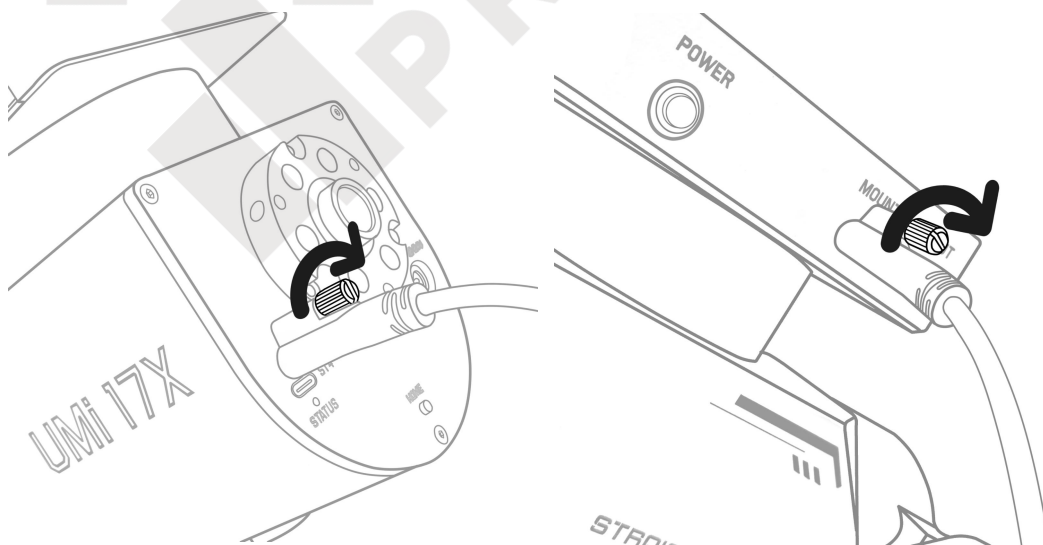

The default saddle configuration on the UMi 17X is compatible with Vixen dovetails. To switch to the Losmandy configuration, unscrew the three M3*8mm screws marked red below, and remove the saddle blocks.

The Losmandy configuration should NOT be used with Vixen dovetails.

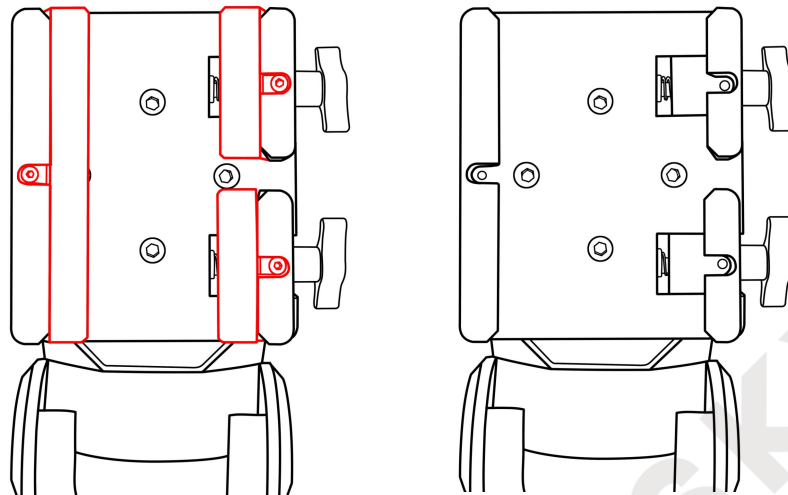

A “STATUS” indicator is located on the front panel of the mount.

Constantly flashing: Tracking enabled

Steady light: Tracking stopped (possibly due to limits) / during GOTO

Green indicator: Equatorial mode

Blue indicator: Alt-Az mode

To use the Proxisky ST4 hand controller with the UMi 17X, a **full-featured** USB Type-C cable and an adapter are required, one of each is included with the mount.

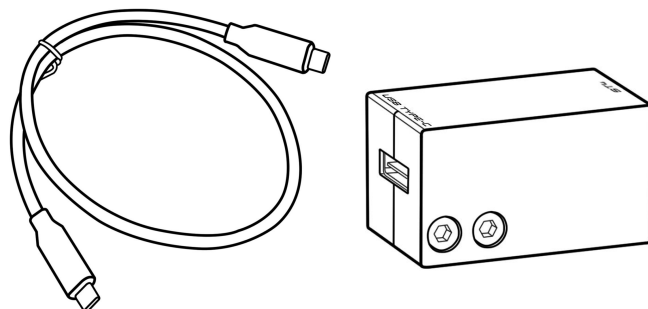

IV. Installation

1. Body Installation (Equatorial & Alt-Az)

a. Equatorial Mode (with Proxisky CF40 tripod)

Fix the silver connection plate of the tripod to the bottom of UMi 17X with at least three M6*10 screws.

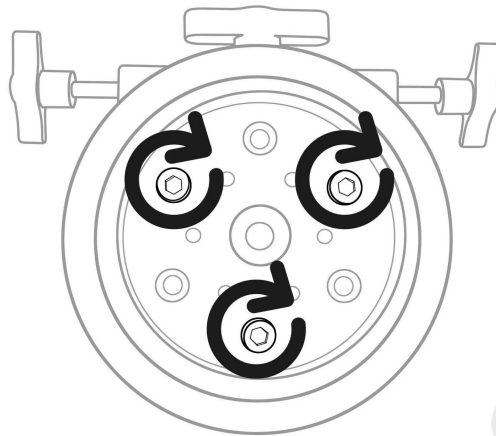

Place the mount assembly onto the tripod, tighten both the silver and black knobs at the bottom, and tighten the three additional black thumb screws (for more detailed instructions please refer to the Installation Guide of the all-new CF40 tripod).

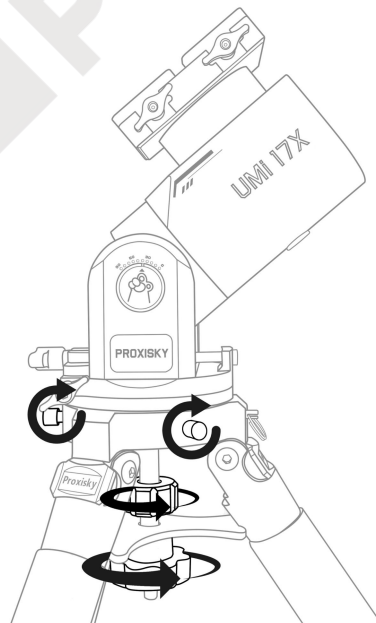

b. Alt-Az Mode (Proxisky CF40 tripod, PE210 pier extension)

Manually adjust the altitude on the UMi 17X all the way to 90° using the rear altitude adjustment knob.

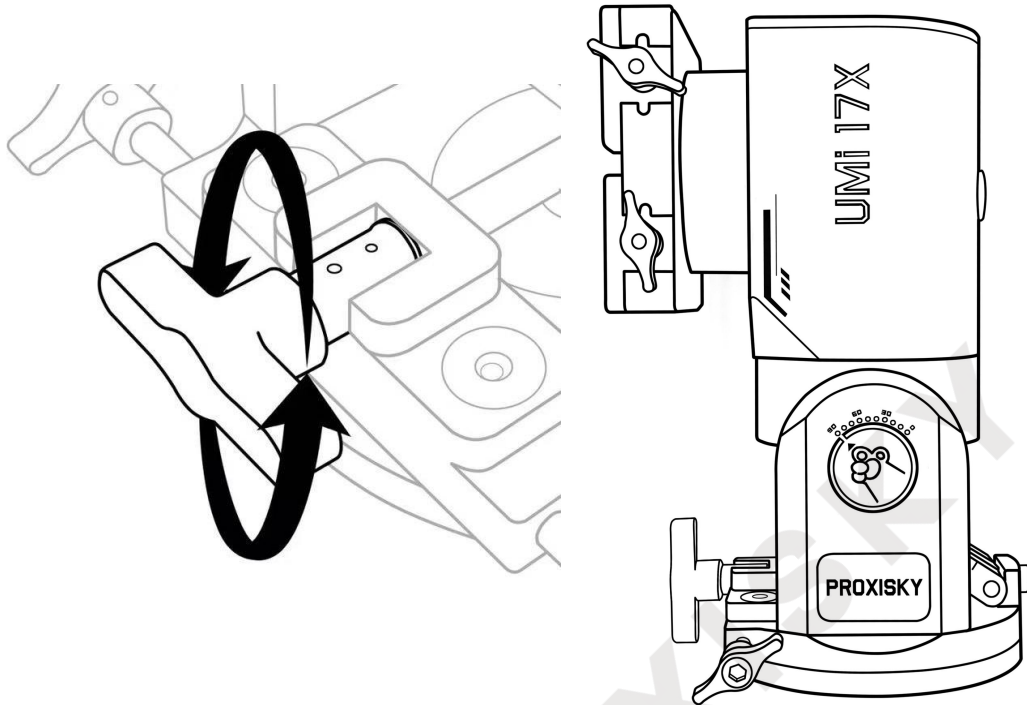

Fix the tripod's silver connection plate to the bottom of PE210 with three M6*10 screws.

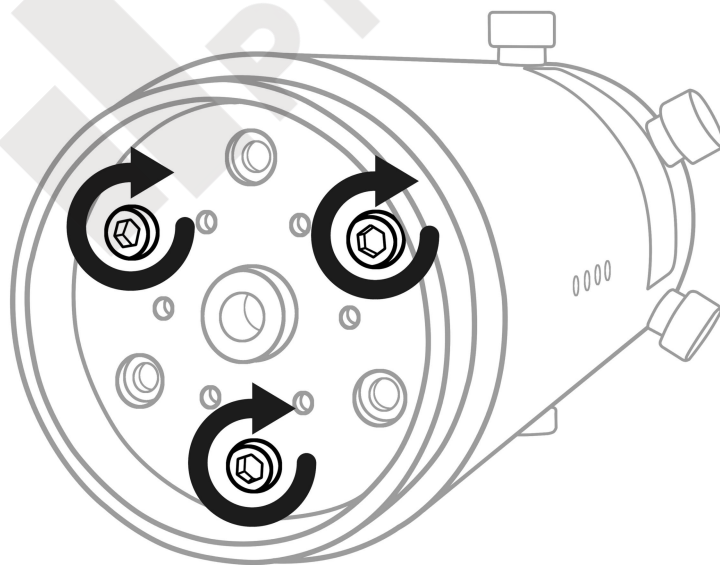

Unscrew the six red thumb screws on the PE210.

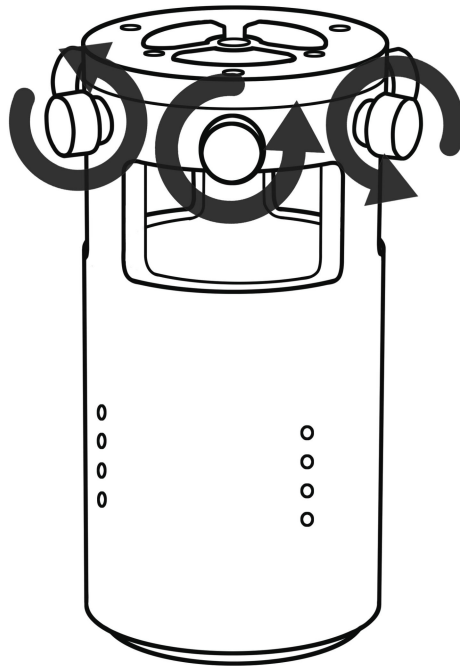

Place the lower half of the PE210 onto CF40 tripod, tighten both the silver and black knob at the bottom, and tighten the three additional black thumb screws.

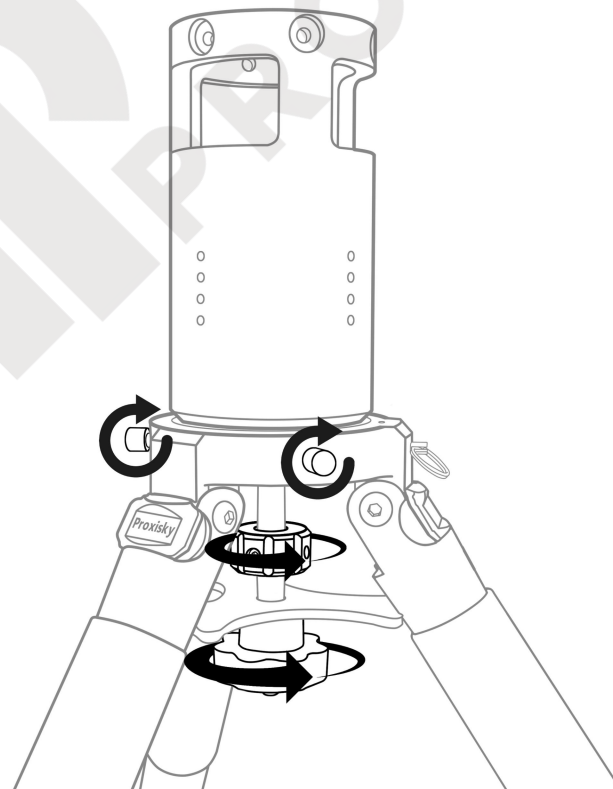

Fix the upper half of PE210 to the bottom of the UMi 17X using three M6*10 screws.

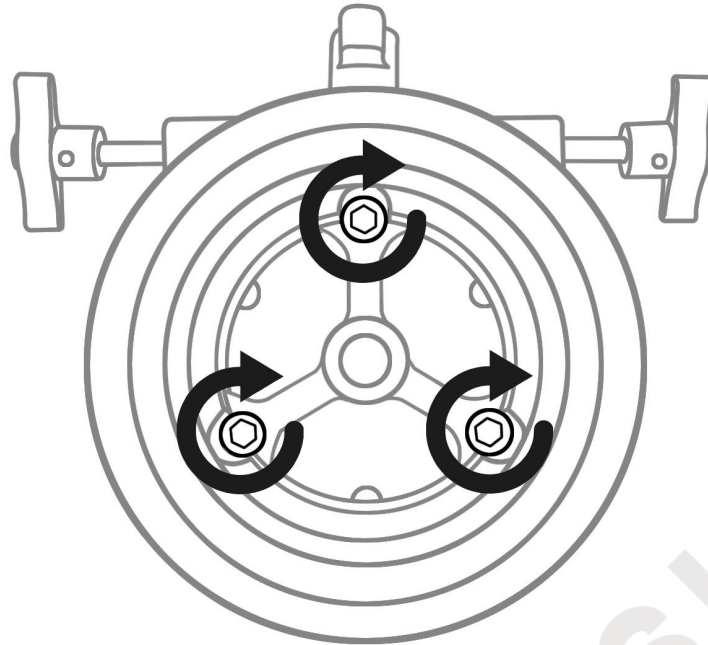

Align the lower half of PE210 with the upper half's screw holes and secure the assembly with the 6 red thumb screws.

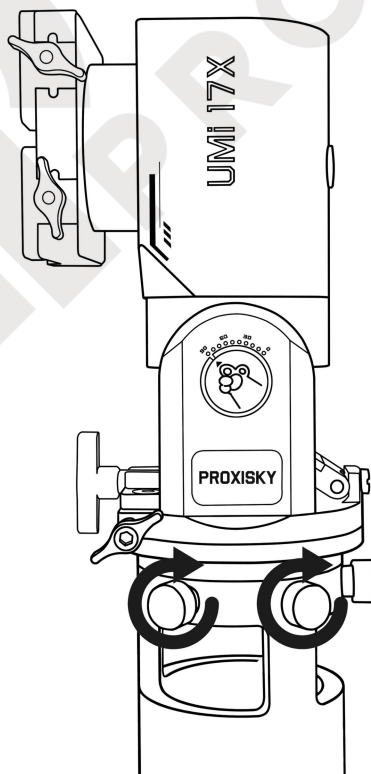

In the UMi Mount app’s settings, under the “mount mode” menu, switch to “AltAzm”, and power-cycle the mount. By switching to Alt-Az mode the UMi 17X will automatically activate and slew to its secondary home position upon restart, pointing Dec sideways due North.

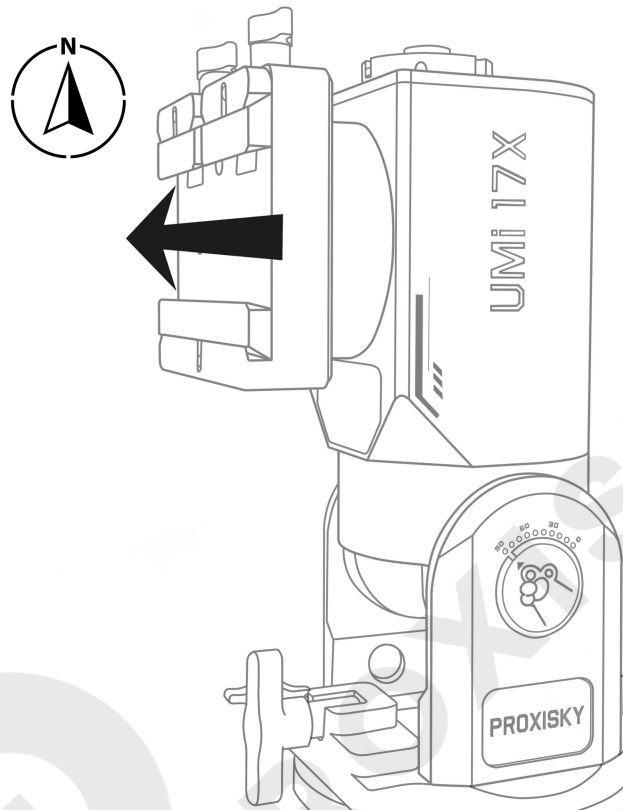

2. Connection

a. Power Input

Insert one end of the male-male power cable into the mount’s DC In port. Plug the other end of the power cable into a DC power supply with at least 3A output at 12-24V. Press down on the mount’s power switch located on the saddle to turn it on. The indicator on the mount will start blinking after initialization, indicating its tracking status.

b. USB Communication

Connect the USB Type-A plug to a PC, ASIAIR or other controlling platform.

Connect the other end (USB Type-C) of the cable to the “Mount” port located on either the front panel or the saddle of the mount.

3. Physical Home

With physical home sensors installed on both RA and Dec, the UMi 17X is able to find the correct home positions each time a homing command is received, regardless of coordinates synced to the mount. Pressing and holding down the physical home button located on the side panel for roughly 3 seconds triggers physical homing. Sensor-based home finding is supported on all platforms, and ASIAIR is now able to trigger home finding as well with targeted optimization done by Proxisky.

4. Secondary Home Position

An additional home sensor is installed on the Declination axis to achieve physical homing for parallel dual-setups. When the secondary home position is activated, home position for Dec axis will have the saddle placed perpendicular to the RA axis, pointing East and West. Switch between primary and secondary home positions with the UMi Mount mobile app under “Home Position” menu, or through the Proxisky Center

PC app. UMi 17X will also automatically enable and slew to its secondary home position when switched to Alt-Az mode after restart, and to its primary home position when switched back to equatorial mode.

5. Physical RA Limits

A physical RA limit sensor is placed on the mount's Right Ascension axis, providing accurate limits that halt any movements on RA when triggered. Despite the sensor being in a fixed position, RA limits on the UMi 17X can still be adjusted via either the UMi Mount app or Proxisky Center PC app. Under extreme circumstances when RA had already slewed past the limit sensor, the mount is able to detect such cases and will spontaneously slew itself back to the currently activated physical home position to prevent potential collisions as soon as the mount is powered on. Note that RA limits are disabled under Alt-Az mode.

6. Physical Dec Limits

To prevent cable snagging inside the mount, Dec limit system is now implemented on the UMi 17X using both sensors on the Declination axis. Similar to RA limits, Dec will now hit the limits after slewing for more than 185 degrees rotating in either direction from the currently activated home position, stopping the mount's tracking status. Use either N or S directional keys to slew Dec away from the limit area. Adjust the limit angles in either the UMi Mount app or Proxisky Center PC app.

7. UMi Mount Mobile App

<https://www.proxisky.com/support.html>

Tip: Connect to the mount's Wi-Fi before launching the app

Wi-Fi name: OnStep Default password: password

8. Setup with ASIAIR

Download "ASIAIR" app in mobile app stores, and install.

a. Via USB

Connect one of the USB Type-A ports on ASIAIR to one of the USB Type-C "Mount" ports on the mount, with the mount powered on. Select OnStep Electronics as the mount, set serial port baud rate to 9600, then select serial port connection on the mount page, as shown below:

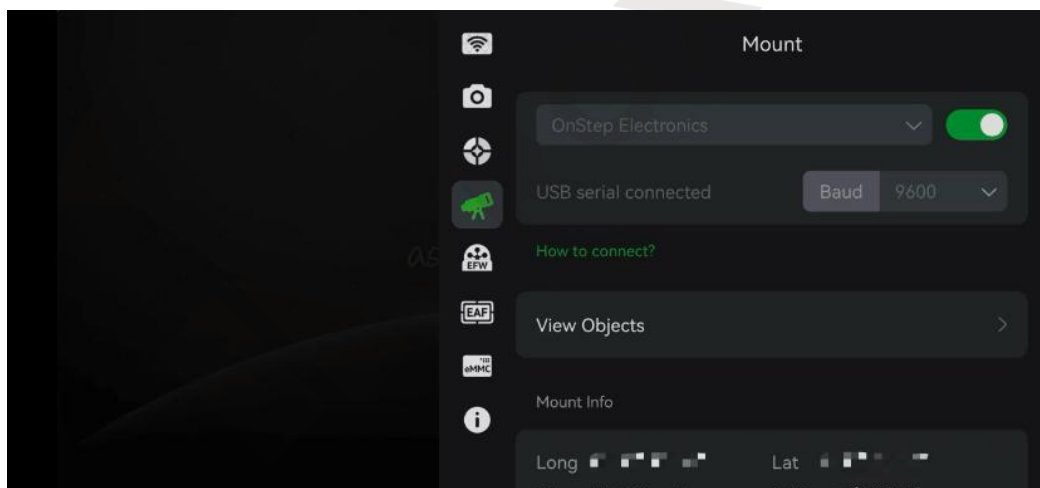

b. Via Wi-Fi

Select and connect to the mount's Wi-Fi within your device settings (Wi-Fi name: OnStep Default password: password)

Select OnStep Electronics as the mount, change the connection mode to

Ethernet, enter 192.168.0.1 as the IP and 9998 as the port, and connect, as shown below:

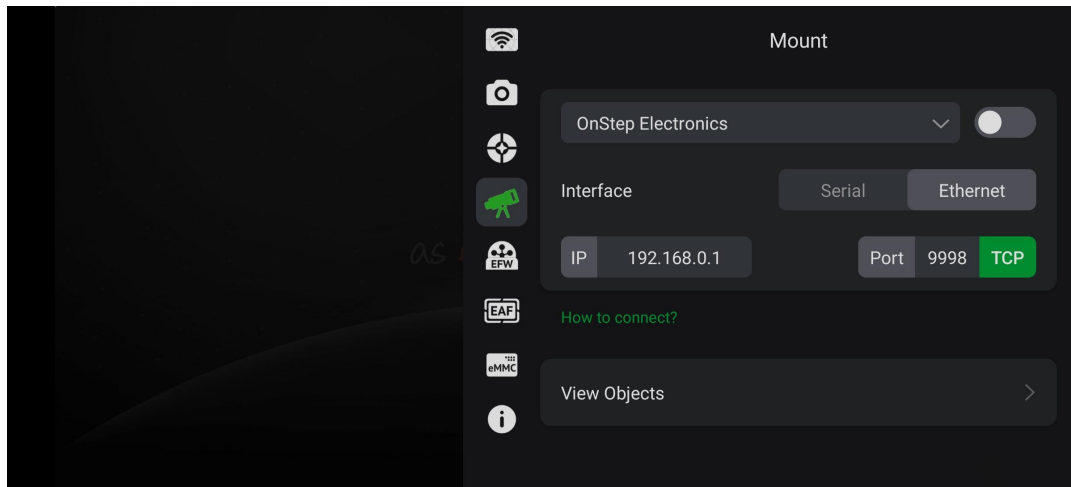

9. Setup with NINA and PHD2

<https://www.proxisky.com/support.html>

V. Related Drawings

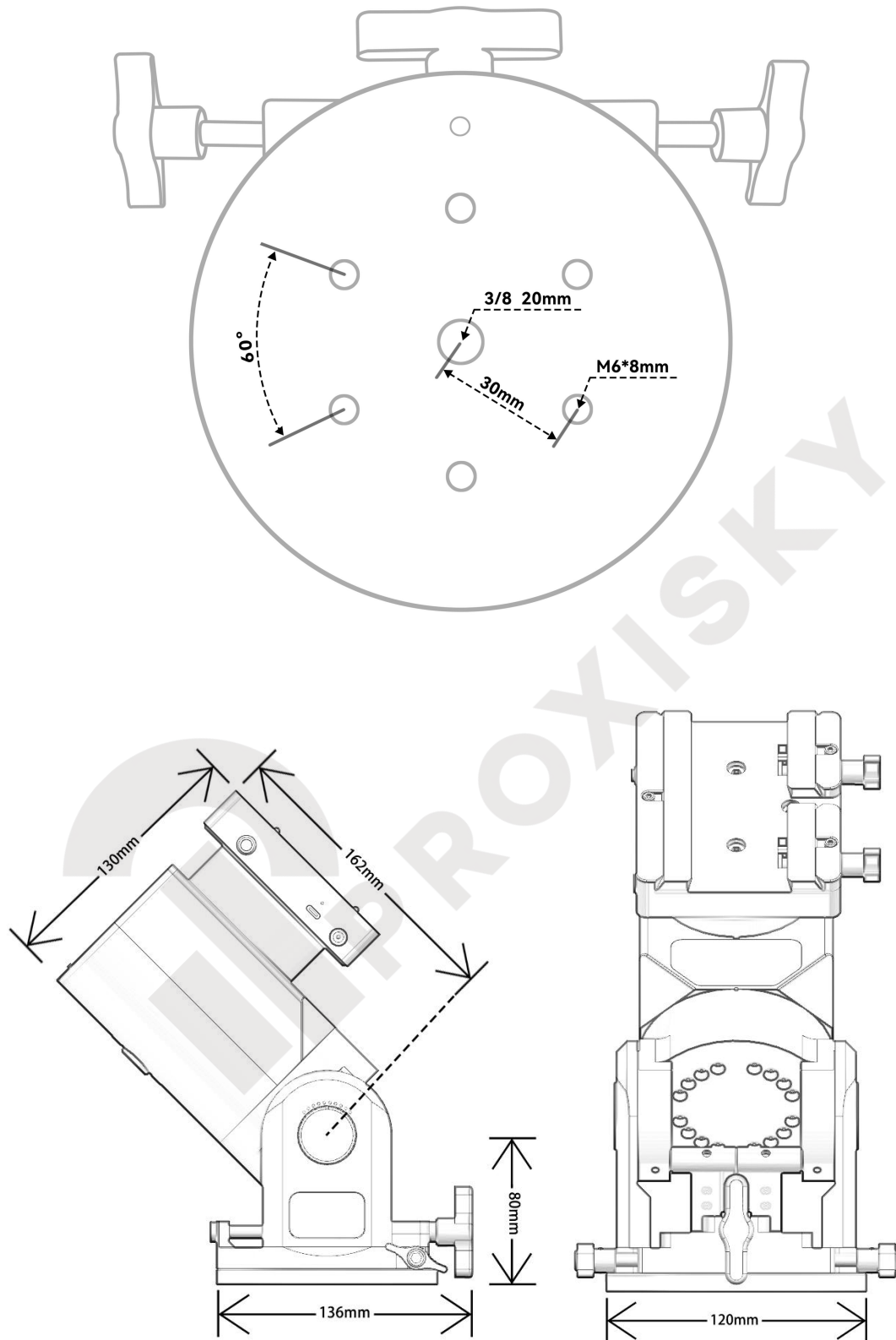

VI. After-sales Services

If you have any questions or need further information, please feel free to visit our official website: <https://www.proxisky.com/>

Or contact Proxisky_Nøkk via Discord.

Official email: info.cn@proxisky.com / nokk@proxisky.com

VII. Warranty

We offer a comprehensive two-year warranty service to ensure you enjoy worry-free protection during use. The warranty period begins on the actual date you receive the product, covering all possible quality issues to ensure your interests are fully protected.

During the warranty period, we promise to repair or replace products with quality issues for free, including but not limited to firmware upgrades, sending replacement parts, factory repairs, and exchanges, to ensure your user experience is optimal. However, our warranty service has some limitations. Specifically:

(1) Damage beyond the free warranty period is not covered by the warranty;

(2) Damage caused by external forces, such as falls or collisions during transportation, is not covered by the warranty;

(3) Damage or product quality issues resulting from not following the product usage guide are not covered by the warranty;



(4) Unauthorized disassembly, third-party repairs, modifications, firmware flashing, etc., without written approval from Proxisky's official after-sales, are not covered by the warranty;

(5) Damage caused by using the product in unsuitable environments, such as water immersion or rain exposure, is not covered by the warranty;

(6) Product damage caused by irresistible external forces is not covered by the warranty;

(7) Products without purchase records from Proxisky or authorized dealers are not covered by the warranty.

For products beyond the free warranty scope, we can offer paid repair services.

For product quality issues, we provide warranty service for products within the warranty period. If you encounter problems during use and need warranty service, please contact us. We will provide the appropriate solution based on the nature of the problem, such as firmware upgrades, sending replacement parts, factory repairs, and exchanges.

For product transportation issues, if you discover obvious deformation or damage to the product's shipping packaging upon receipt, you should immediately contact the official mall or authorized dealer from which you ordered. After confirmation, you can refuse to accept the product and have the carrier return it, and we or the authorized dealer will provide return or exchange services. If you discover damage to the

product after signing for it, you also need to provide proof of the product's external packaging or a third-party certificate from the carrier. After verification and confirmation that the damage was caused during transportation, we or the authorized dealer will provide the corresponding return or exchange service.

We always strive to provide high-quality products and excellent service to our customers. Our warranty policy is our commitment to our customers, ensuring you receive the highest level of protection while using our products.